

Area of Application

ESSVE ECS Concrete Screw is an affordable concrete screw for simpler applications where the assembly does not require e.g. ETA approval.

Description

ECS is a hardened concrete screw that is pulled directly into a pre-drilled hole, without a plug. It has a so-called hi-Low thread That deliver good load values and Facilitates assembly. The concrete screw is made from hardened steel.

The surface treatment is electro zinc plated, which gives 15 years of resistance in corrosivity classification C1. Which corresponds to installation indoors in heated areas with dry air and insignificant amount of impurities. e.g. offices, shops, schools, hotels. According to SS-EN ISO 9223 and SS-EN ISO 12944-2

Installation

When mounting, an impact screwdriver is recommended. See installation instructions. The concrete screw does not require a pre-

ad torque to ensure the fixing, which means that when the screw has reached the surface, all tightening must be avoided. The final torque applied shall not be greater than that required to hold what is to be fixed in place. The tightening torque specified is the maximum torque, not to be confused with other products that require a preload operation.

The ECS concrete screw is through hardened and therefore sensitive to oblique mounting. The bore shall be 90 degrees to the substrate. ESSVE ECS Concrete Screw has no requirement for blowing of borehole before installation, but the borehole must be deep enough to assemble the Concrete screw in along with the dust that is left behind. Otherwise, the screw will not be mounted to the right depth. ESSVE ECS Concrete Screw has no requirement for purging of borehole before installation, but the bore must be deep enough to assemble the Concrete screw in along with the dust that is left behind. Otherwise, the screw will not be mounted to the right depth.



Installation

1. Drill a hole. Roughly clean the drill hole from drill cuttings by moving the hammer drill back and forth 2-3 times.
2. Tighten the screw with a TX drive/bits or sleeve. An impact screw driver is recommended for dimensions 6.3 and 7.5 mm. An impact wrench is recommended for dimensions 10.5 and 16.5 mm.
3. The installation is finished.

Specification

Material	Steel C1022 Surface hardening 450-800 HV/ core 320-450 HV	Steel C1022 Surface hardening 450-800 HV/ core 320-450 HV
Surface treatment	Bright zinc plated	CorrSeal
Corrosion categories	C1	C4

Recommended fixing depth*)

Material	Ø 7.5	Ø 6.3
Concrete	35/50 mm	25 mm
Brick	50 mm	40 mm
Hollow core elements	60 mm	50 mm

*) Drill depth = fixing depth + min. 10 mm

Practical load capacity

Dimension mm Ø	Installation depth mm	Tension load kg Concrete C20/25	Tension load kg Hollow deck element C60/75*	Shear load kg Concrete C20/25	Shear load kg Hollow deck element C60/75*	Min. edge distance Tensile load mm	Min. edge distance Transverse load mm	Min. spacing mm	Tightening torque** Nm
6,3	25	80		140		40	50	100	5
7,5	35	100	110	260	340	60	80	140	15
7,5	50	240		260		60	80	140	15

* Installed directly over the channel = min. concrete thickness of the element

Applied safety factors are in accordance with Boverket's General Guidelines 1993:1, Type approval of fixings.

Design load capacity according to Eurocode

Dimension mm	Installation depth mm	Tension load Concrete C20/25 kN	Tension load Hollow deck element C60/75* kN	Shear load Concrete C20/25 kN	Shear load Hollow deck element C60/75* kN	Min. edge distance Tensile load mm	Min. edge distance Transverse load mm	Min. spacing mm
6,3	25	1,1		1,8		40	50	100
7,5	35	1,3	1,5	3,4	4,5	60	80	140
7,5	50	3,2		3,4		60	80	140

* Installed directly over the channel = min. concrete thickness of the element.

Fire rating

Dim. 7.5 is approved for fire rating R30 for a load of 1.0 kN. Min. installation depth of 35 mm.

Concrete screw, hex head with flange, BZP

Technical data and ESSBOX pack

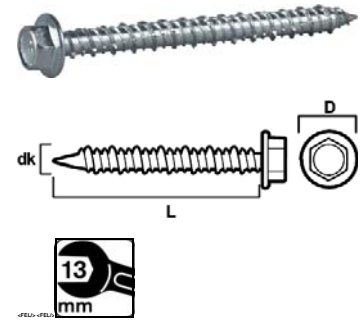

Item no.	Dimension dk x L mm	D mm	Drill Ø mm	Drill depth* mm	Maximum detail thickness* mm	Key width mm	ESSBOX size	Qty./ pack.	Pack./ large pack.
105237	7,5×40	14,5	6	45/-	5/-	10	204	100	6
105227	7,5×40	17,5	6	45/-	5/-	13	204	100	6
105238	7,5×50	14,5	6	45/-	15/-	10	204	100	6
105239	7,5×80	14,5	6	45/60	45/30	10	304	100	4
105229	7,5×80	17,5	6	45/60	45/30	13	206	100	4
105236	7,5×100	14,5	6	45/60	65/50	10	304	100	4

* At recommended fixing depth in concrete